



2501 Northchase Pkwy SE
Wilmington, NC 28405

(LOUVERED) STEEL DOOR OUTSWING "IMPACT"

GENERAL NOTES

- This product has been evaluated and is in compliance with the 5th Edition (2014) Florida Building Code (FBC) structural requirements excluding the "High Velocity Hurricane Zone" (HVHZ).
- Product anchors shall be as listed and spaced as shown on details. Anchor embedment to base material shall be beyond wall dressing or stucco.
- When used in areas requiring wind borne debris protection, this product complies with Section 1609.1.2 of the FBC and does not require an impact resistant covering. This product meets missile level "D" and includes Wind Zone 4 as defined in ASTM E1996 and Section 1609.1.2.2 of the FBC.
- Site conditions that deviate from the details of this drawing require further engineering analysis by a licensed engineer or registered architect.

TABLE OF CONTENTS

SHEET#	DESCRIPTION
1	Typical elevations, design pressures, & general notes
2	Door panel details
3	Elevations
4	Horizontal cross sections
5	Horizontal cross sections
6	Horizontal and vertical cross sections
7	Anchoring details
8	Anchoring details
9	Anchoring details
10	Components
11	Bill of materials and components

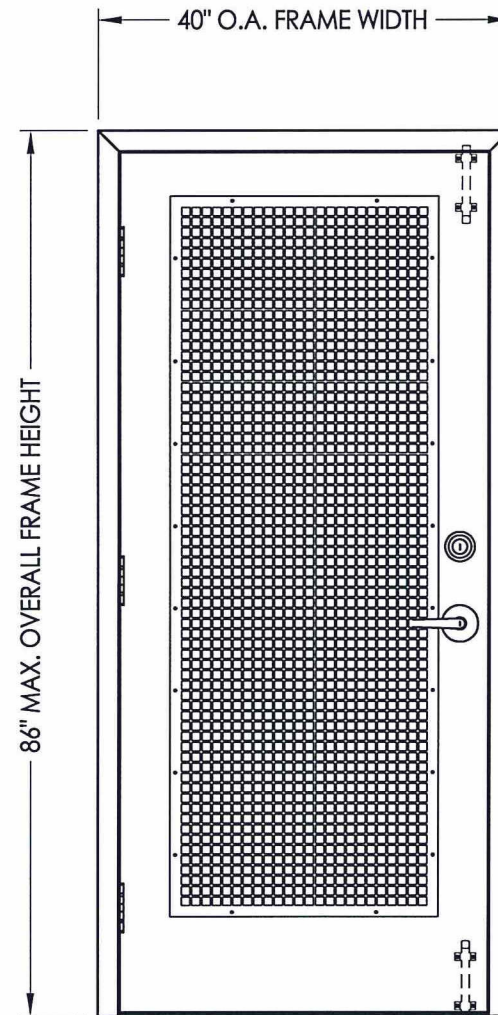

X

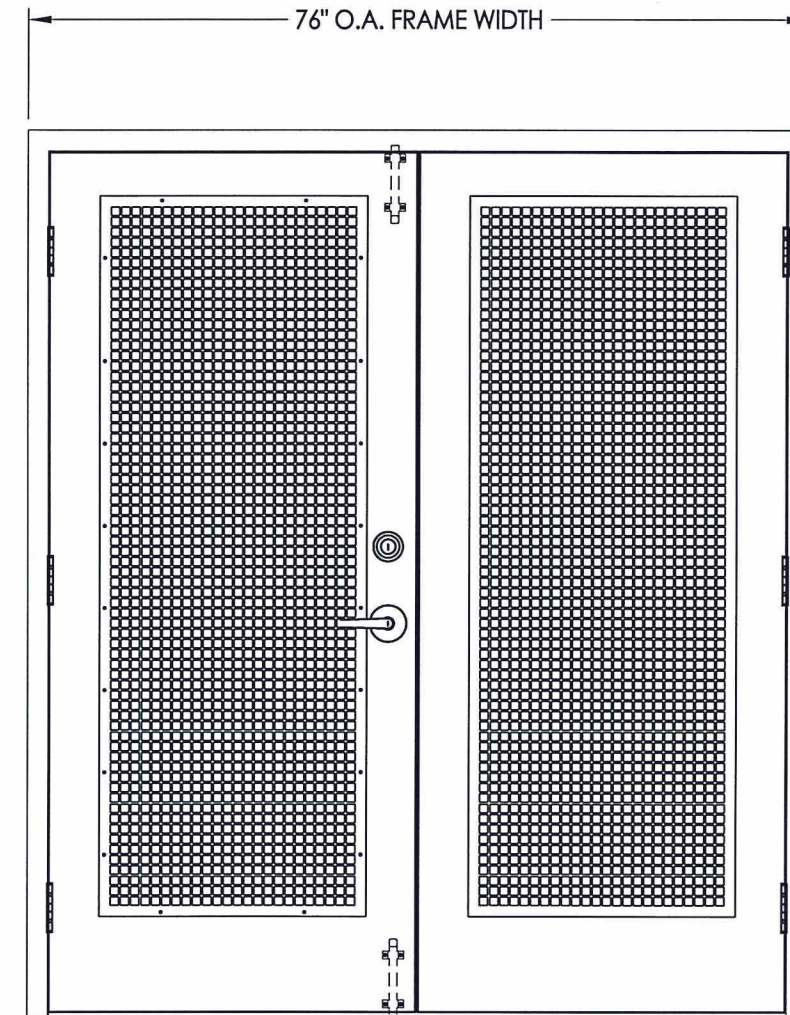

XX

MAX. OVERALL DIMENSION	DESIGN PRESSURE (PSF)	
	POSITIVE	NEGATIVE
40.0" X 86.0"	+65.0	-70.0
76.0" X 86.0"	+55.0	-55.0

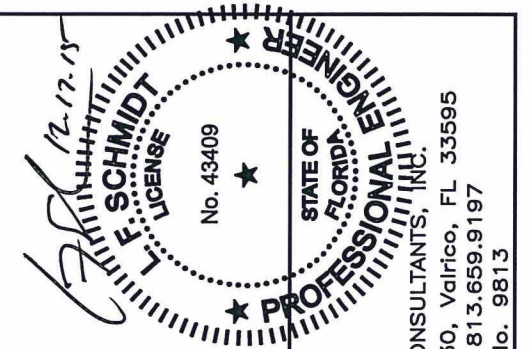

Documents Prepared By:
Lyndon F. Schmidt
P.E. No. 43409

RW
BUILDING CONSULTANTS, INC.
P.O. Box 230, Vairico, FL 33595
Phone No.: 813.659.9197
FBPE C.A. No. 9813

PRODUCT: HMF EXPRESS

PART OR ASSEMBLY: TYPICAL ELEVATIONS, DESIGN PRESSURES & GENERAL NOTES

NO.	DATE	BY	REVISIONS

DATE: 12/11/15
SCALE: N.T.S.
DWG. BY: JK
CHK. BY: LFS
DRAWING NO.: FL-18506.8
SHEET 1 OF 11

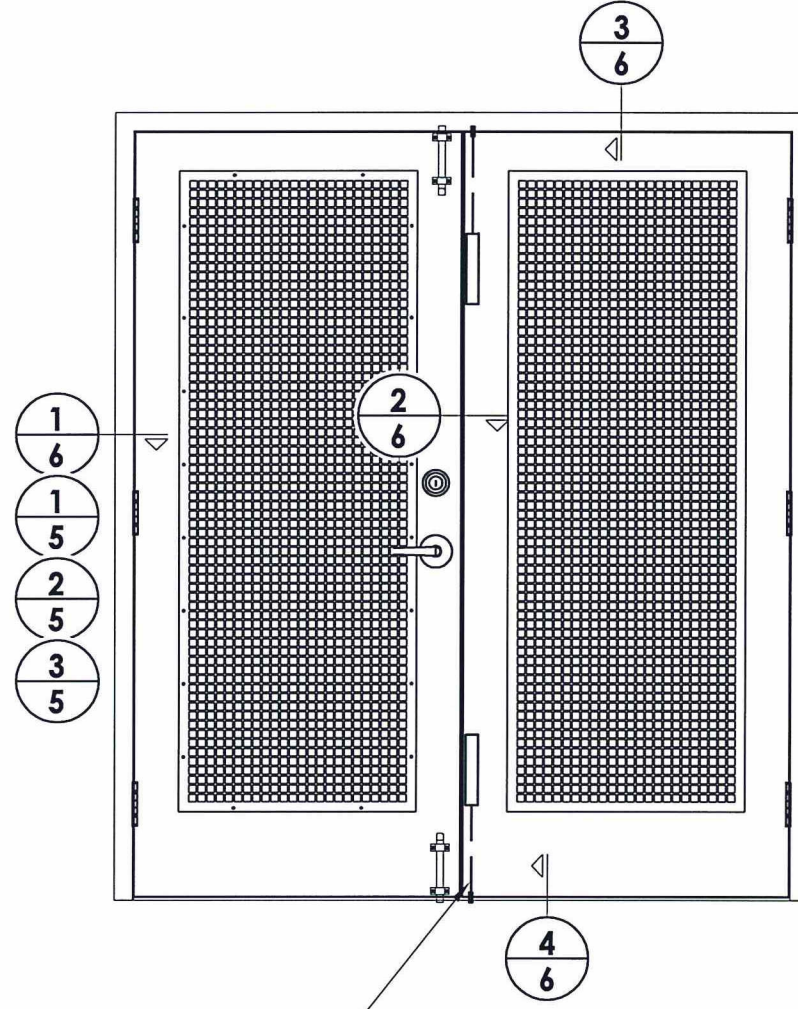
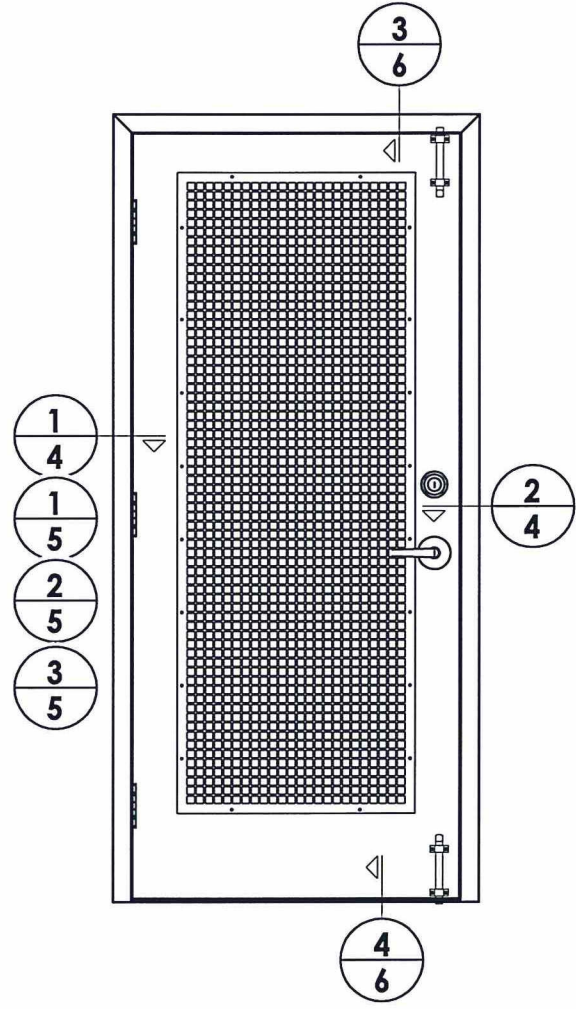

ROCKWELL 555 FLUSH BOLT @ head and sill
w/ 3/4" throw. Mortise strike plates (15/16" x 2-1/4")
attached to frame head and aluminum threshold
w/ (2) #8 comb. ws/sms each.

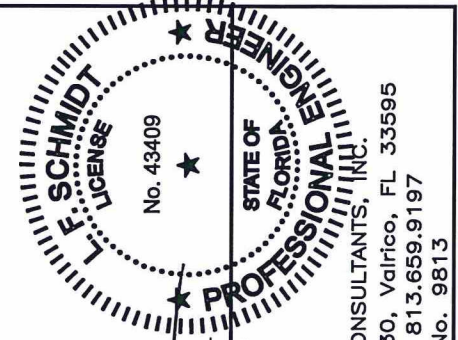

LFS
12-17-15
Documents Prepared By:
Lyndon F. Schmidt
P.E. No. 4-3409
RW
BUILDING CONSULTANTS, INC.
P.O. Box 230, Valrico, FL 33595
Phone No.: 813.659.9197
FBPE C.A. No. 9813

PRODUCT:	HMF EXPRESS	
PART OR ASSEMBLY:	ELEVATIONS	
NO.	DATE	BY
REVISIONS		
DATE:	12/11/15	
SCALE:	N.T.S.	
DWG. BY:	JK	
CHK. BY:	LFS	
DRAWING NO.:	FL-18506.8	
SHEET	3	OF 11

NOTES:

- Spot weld anchor bracket to frame:
2 welds per flange (4 total per bracket).

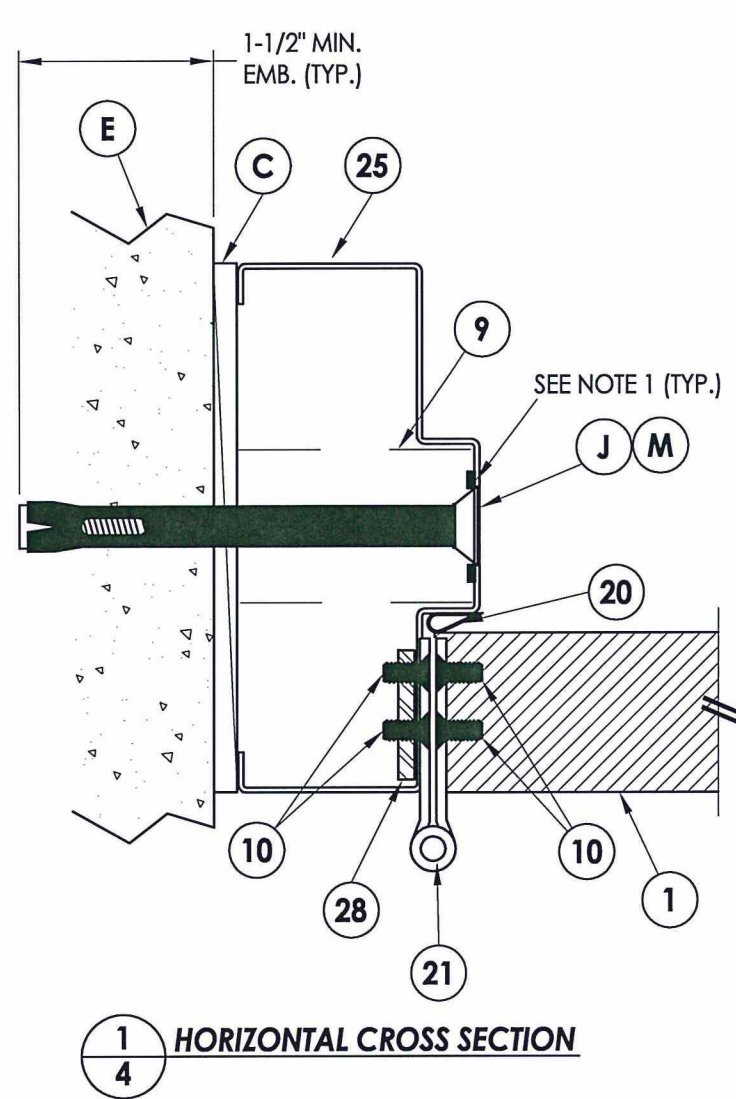

1
4 HORIZONTAL CROSS SECTION

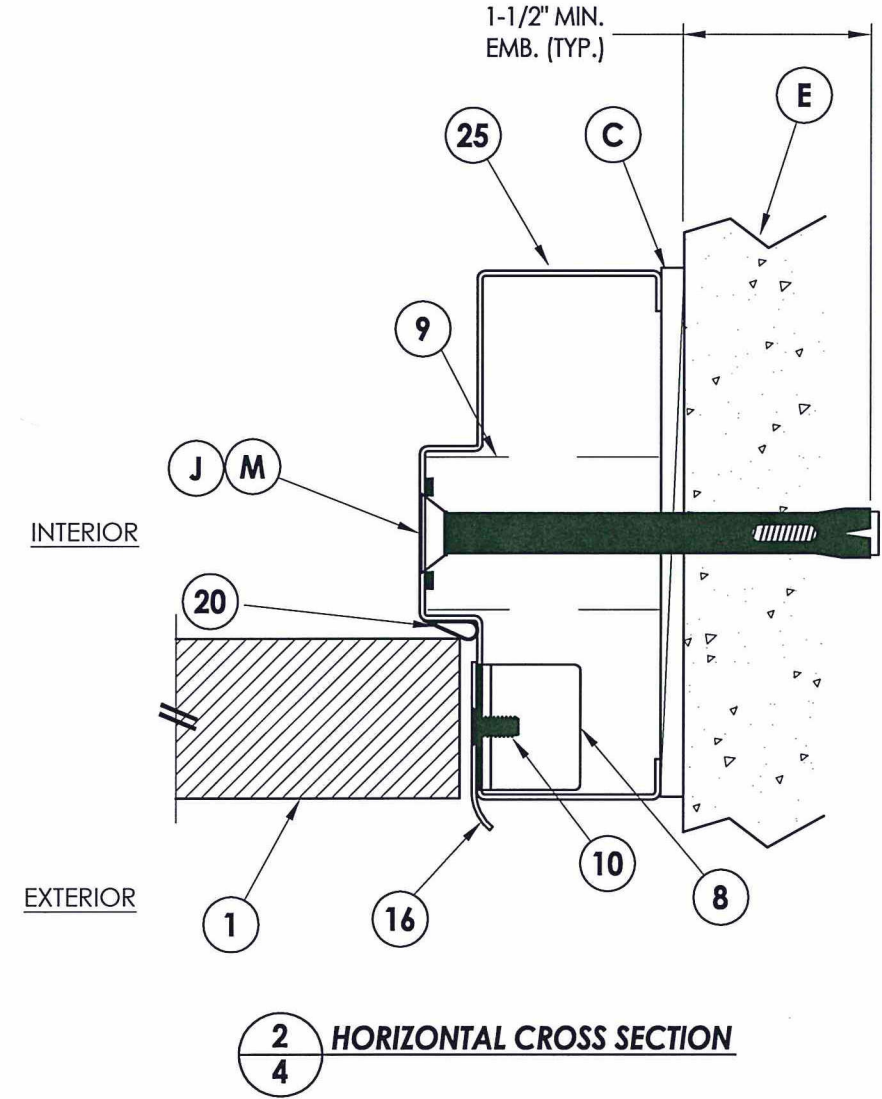

2
4 HORIZONTAL CROSS SECTION

LFS
 12.11.15

Documents Prepared By:
 Lyndon F. Schmidt
 P.E. No. 43409

RW
 BUILDING CONSULTANTS, INC.
 P.O. Box 230, Valrico, FL 33595
 Phone No.: 813.659.9197
 FBPE C.A. No. 9813

	PRODUCT:	HMF EXPRESS		
	PART OR ASSEMBLY:	HORIZONTAL CROSS SECTIONS		
	NO.	DATE	BY	REVISIONS
DATE: 12/11/15				
SCALE: N.T.S.				
DWG. BY: JK				
CHK. BY: LFS				
DRAWING NO.: FL-18506.8				
SHEET 4 OF 11				

R:\Clients\HMF Express PERMANENTVA - Florida Product Approvals\FL-18506\C - Drawings\FL-18506 (2014)\FL-18506.8.dwg, 5.1 (2)

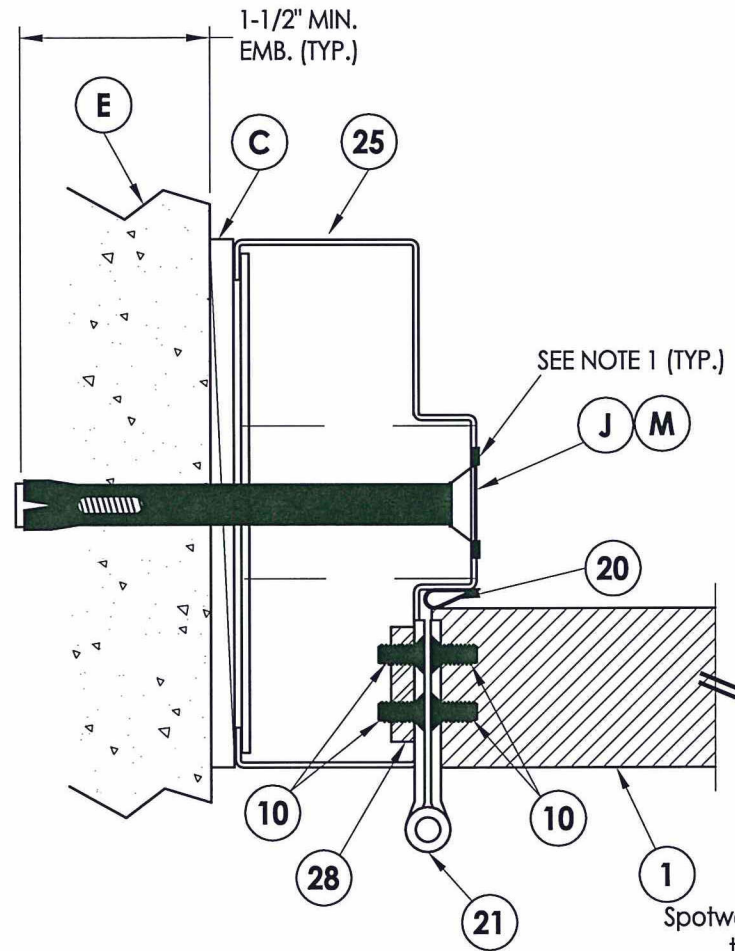

1
6 HORIZONTAL CROSS SECTION

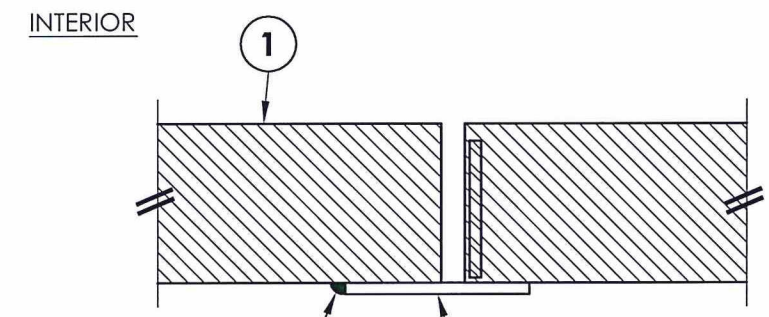

2
6 HORIZONTAL CROSS SECTION

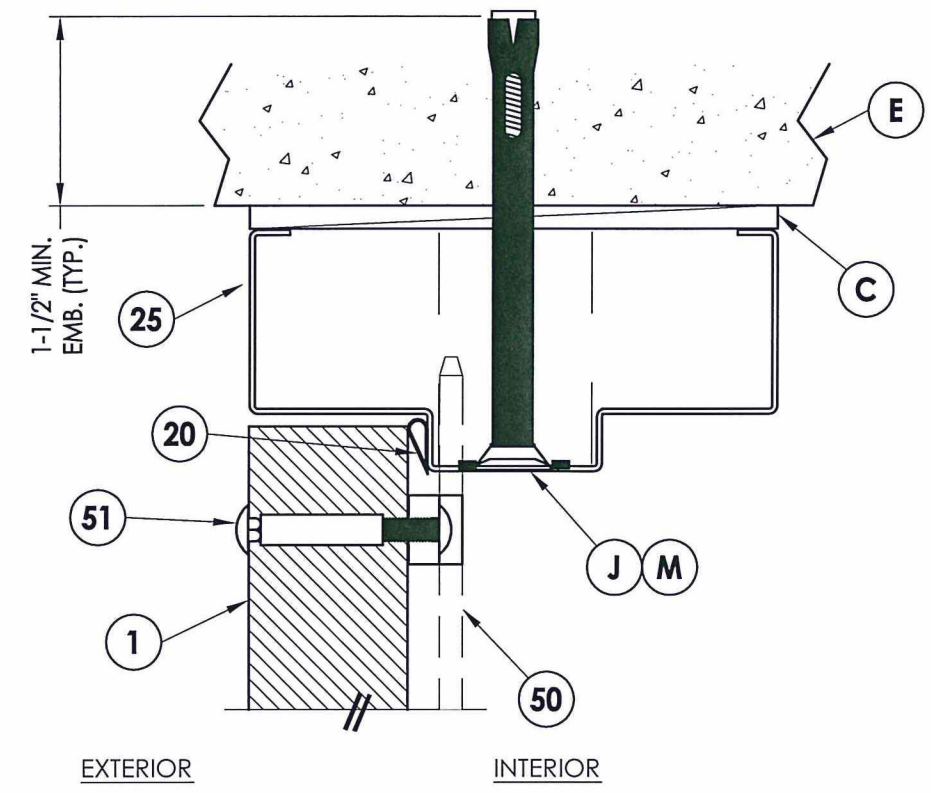

3
6 VERTICAL CROSS SECTION

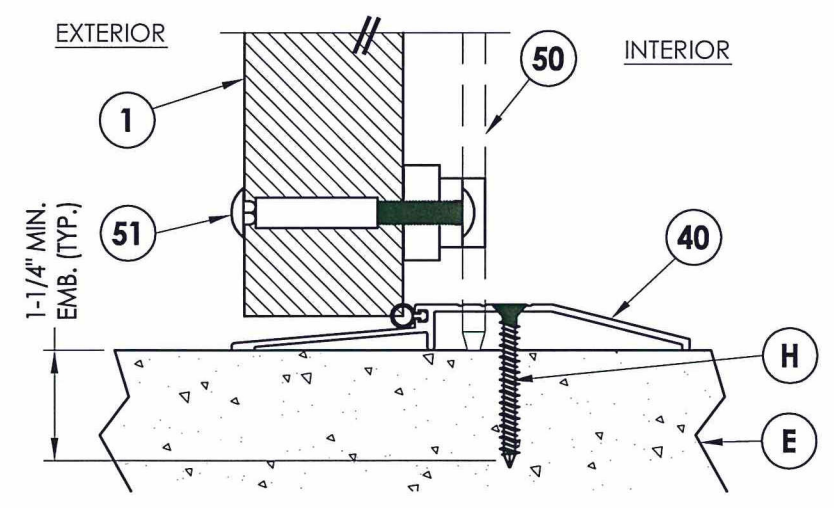

4
6 VERTICAL CROSS SECTION

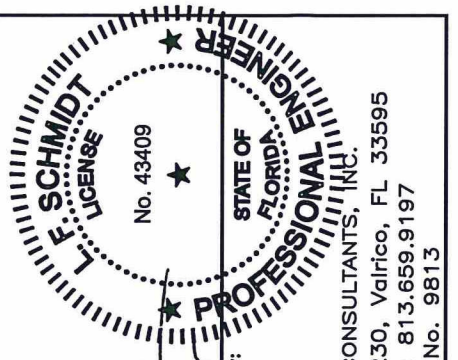

Documents Prepared By:
Lyndon F. Schmidt
P.E. No. 43409

R.W. BUILDING CONSULTANTS, INC.
P.O. Box 230, Vairico, FL 33595
Phone No.: 813.659.9197
FBPE C.A. No. 9813

PRODUCT: HMF EXPRESS

PART OR ASSEMBLY: HORIZONTAL & VERTICAL CROSS SECTIONS

NO.	DATE	BY

DATE: 12/11/15
SCALE: N.T.S.
DWG. BY: JK
CHK. BY: LFS
DRAWING NO.: FL-18506.8
SHEET 6 of 11

R:\Clients\HMF Express PERMANENT\A - Florida Product Approvals\FL-18506C - Drawings\FL-18506 (2014)\FL-18506.8.dwg, 6.1

THE ENGINEER OR ARCHITECT OF RECORD TO DETERMINE FRAMING REQUIREMENTS BASED ON WIND LOADS AND THE CLADDING BEING USED

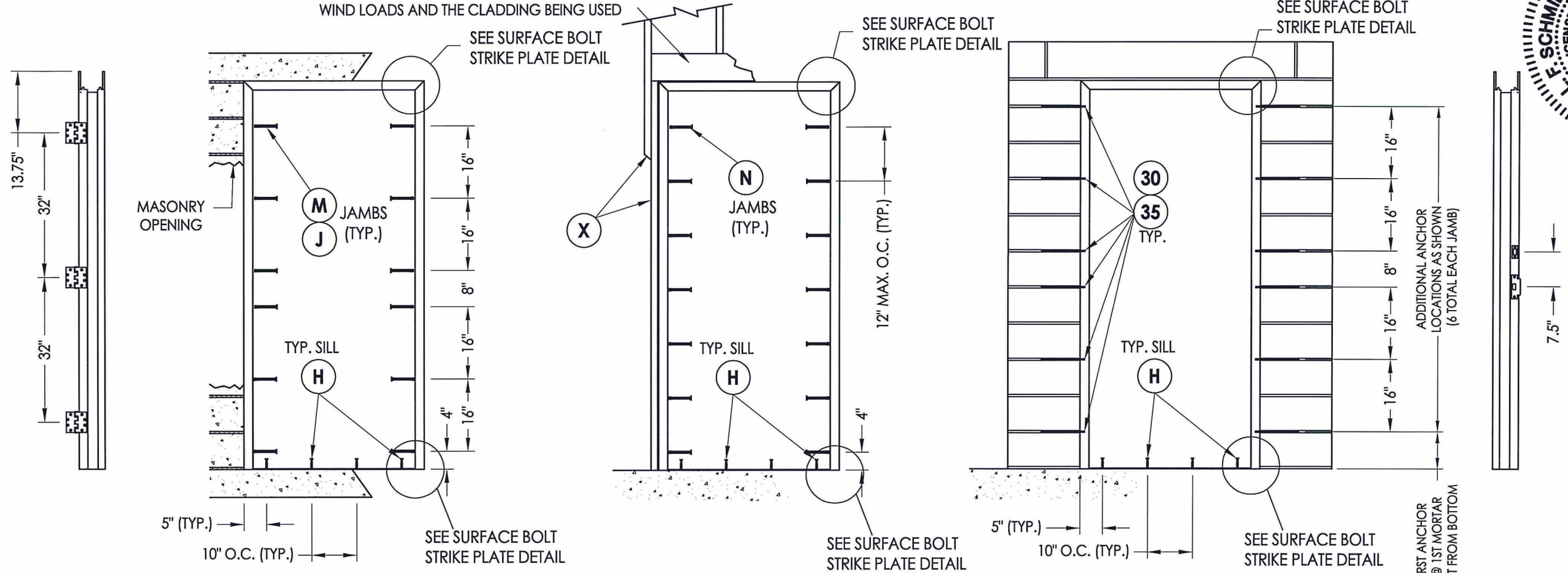

HINGE JAMB

FRAME ANCHORING
Masonry Construction
Concrete Anchors

FRAME ANCHORING
Steel Stud

FRAME ANCHORING
Masonry Construction
Concrete Anchors

STRIKE JAMB

CONCRETE ANCHOR NOTES:

- Concrete screw locations may be adjusted to maintain a minimum 1" edge distance to mortar joints. If concrete screw locations noted as "MAX. O.C." must be adjusted to maintain the minimum edge distance to mortar joints, additional concrete screws may be required to ensure the maximum on center dimension is not exceeded.
- Concrete anchor table:

ANCHOR TYPE	ANCHOR LOCATION	ANCHOR SIZE	MANUFACTURER	MIN. EDGE DISTANCE	MIN. EMBEDMENT
CONCRETE ANCHOR SCREW	JAMBS	3/8"	LDT TAPCON® (ITW BUILDEX)	3"	1-1/2"
	SILL	1/4"	TAPCON® (ITW BUILDEX) ULTRACON® (ELCO) CRETE-FLEX® (ELCO) TAPPER+® (POWERS)	2-1/2"	1-1/4"
	JAMBS	3/8"	DYNABOLT SLEEVE ANCHOR® (ITW REDHEAD)	2-1/4"	1-1/2"

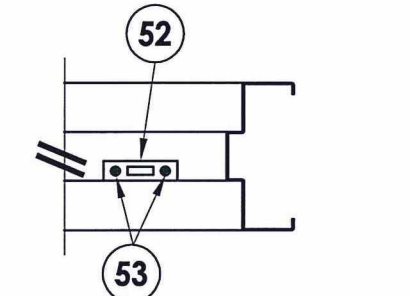

SURFACE BOLT STRIKE PLATE @ HEAD

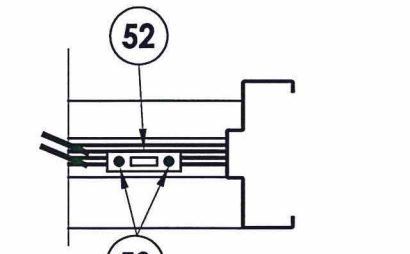

SURFACE BOLT STRIKE PLATE @ SILL

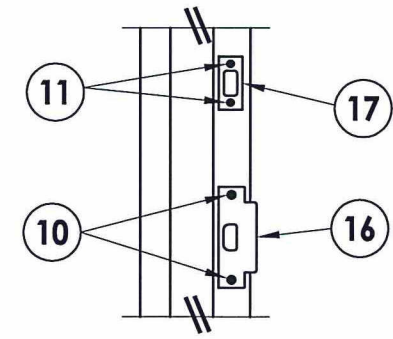

STRIKE DETAIL

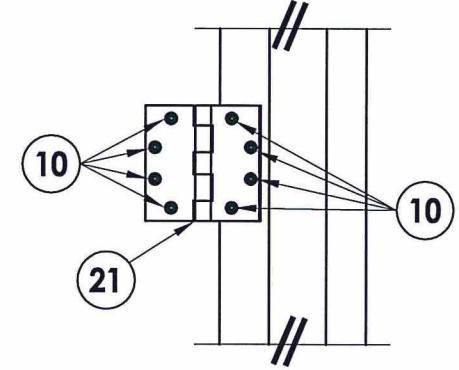

HINGE DETAIL

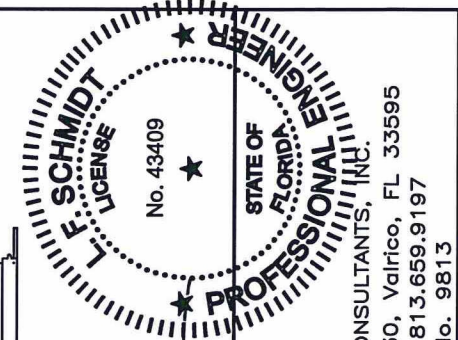

Documents Prepared By:
Lyndon F. Schmidt
P.E. No. 43409

12.11.15
LFS

PRODUCT: HMF EXPRESS
PART OR ASSEMBLY: ANCHORING DETAILS

NO.	DATE	BY

DATE: 12/11/15
SCALE: N.T.S.
DWG. BY: JK
CHK. BY: LFS
DRAWING NO.: FL-18506.8
SHEET 7 OF 11

RW BUILDING CONSULTANTS, INC.
P.O. Box 230, Valrico, FL 33595
Phone No.: 813.659.9197
FBPE C.A. No. 9813

R:\Clients\HMF Express PERMANENT\A - Florida Product Approvals\FL-18506\C - Drawings\FL-18506 (2014)\FL-18506.8.dwg, 7.1

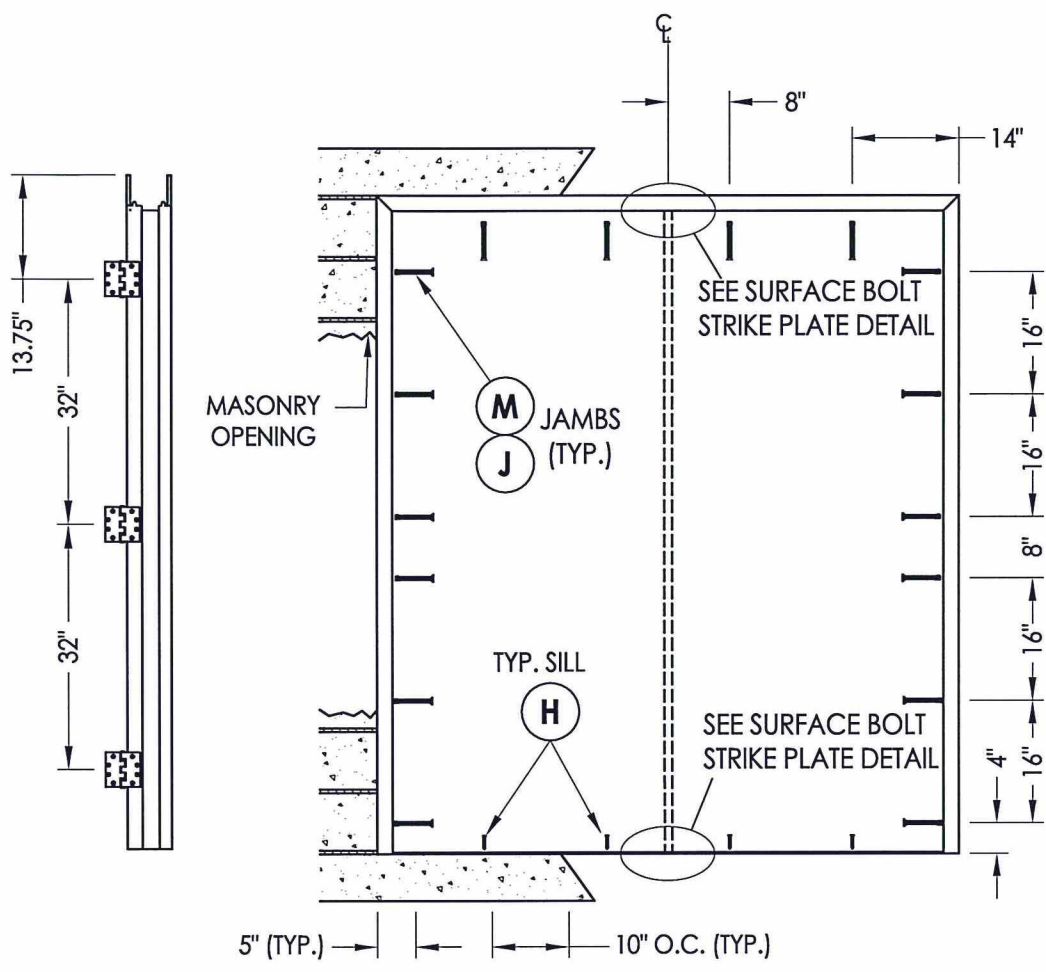

HINGE JAMB

FRAME ANCHORING
Masonry Construction
Concrete Anchors

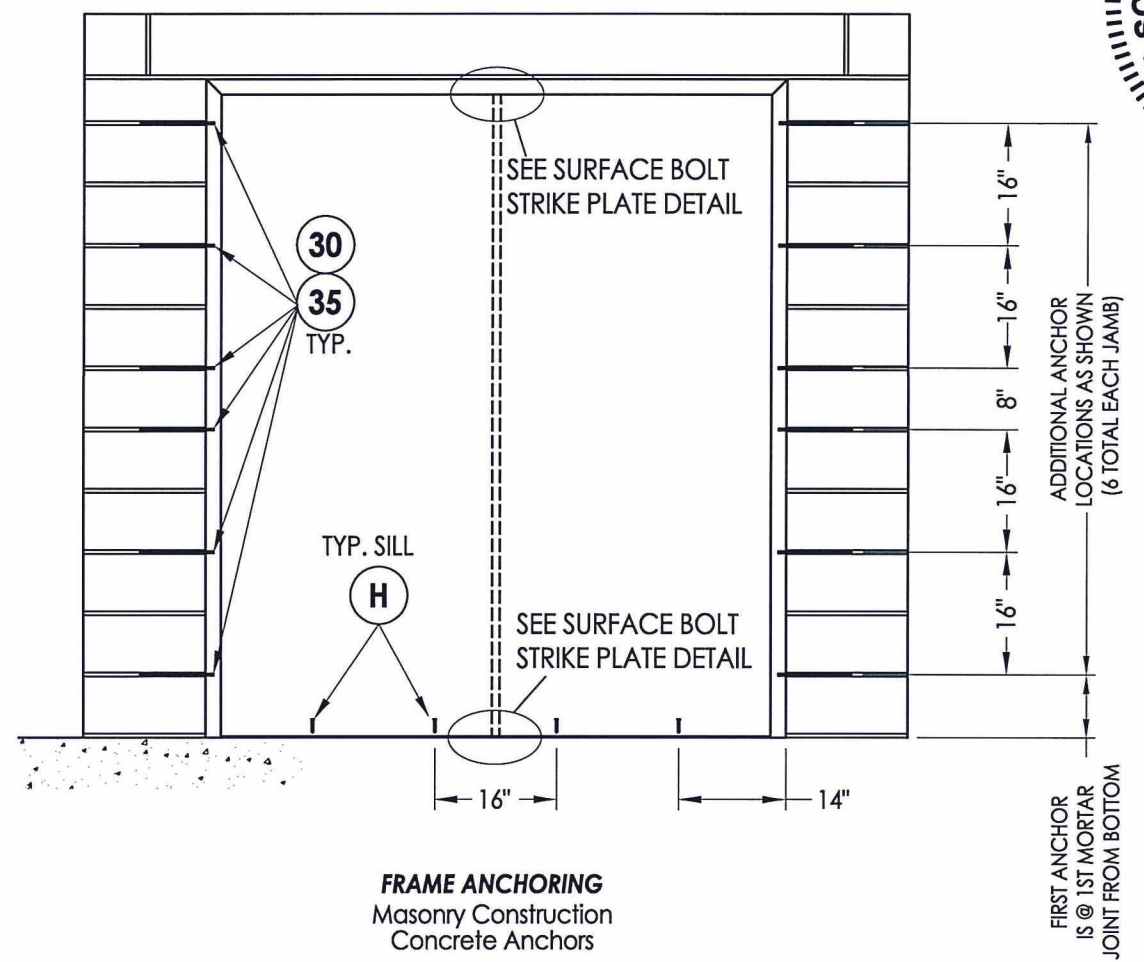

FRAME ANCHORING
Masonry Construction
Concrete Anchors

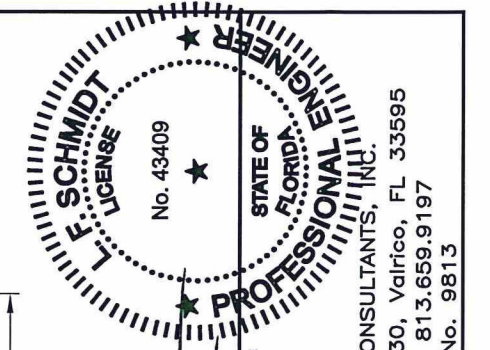

Documents Prepared By:
Lyndon F. Schmidt
P.E. No. 43409
RW BUILDING CONSULTANTS, INC.
P.O. Box 230, Valrico, FL 33595
Phone No.: 813.659.9197
FBPE C.A. No. 9813

PRODUCT:	HMF EXPRESS
PART OR ASSEMBLY:	ANCHORING DETAILS

NO.	DATE	BY	REVISIONS

CONCRETE ANCHOR NOTES:

- Concrete screw locations may be adjusted to maintain a minimum 1" edge distance to mortar joints. If concrete screw locations noted as "MAX. O.C." must be adjusted to maintain the minimum edge distance to mortar joints, additional concrete screws may be required to ensure the maximum on center dimension is not exceeded.
- Concrete anchor table:

ANCHOR TYPE	ANCHOR LOCATION	ANCHOR SIZE	MANUFACTURER	MIN. EDGE DISTANCE	MIN. EMBEDMENT
CONCRETE ANCHOR SCREW	JAMBS	3/8"	LDT TAPCON® (ITW BUILDEX)	3"	1-1/2"
	SILL	1/4"	TAPCON® (ITW BUILDEX) ULTRACON® (ELCO) CRETE-FLEX® (ELCO) TAPPER+® (POWERS)	2-1/2"	1-1/4"
	JAMBS	3/8"	DYNABOLT SLEEVE ANCHOR® (ITW REDHEAD)	2-1/4"	1-1/2"

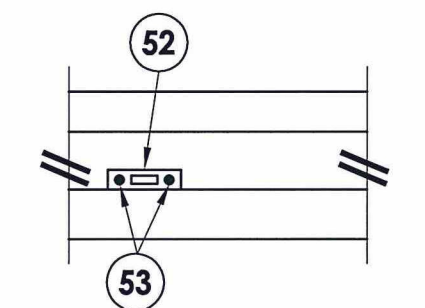

SURFACE BOLT STRIKE PLATE @ HEAD

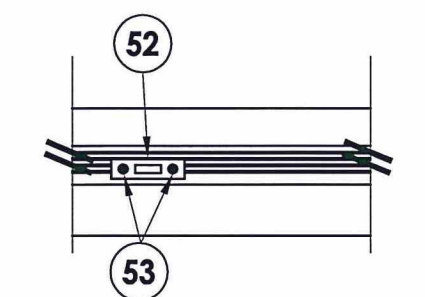

SURFACE BOLT STRIKE PLATE @ SILL

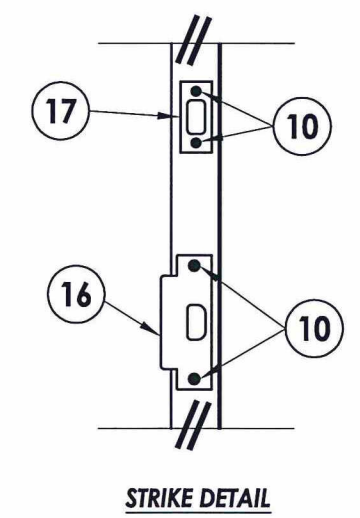

STRIKE DETAIL

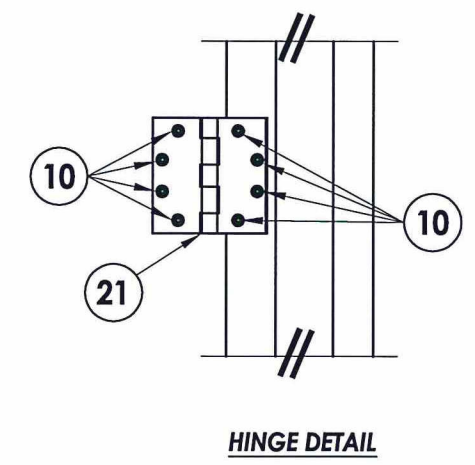

HINGE DETAIL

DATE:	12/11/15
SCALE:	N.T.S.
DWG. BY:	JK
CHK. BY:	LFS
DRAWING NO.:	FL-18506.8
SHEET	8 OF 11

R:\Clients\HMF Express PERMANENTIA - Florida Product Approvals\FL-18506\Drawings\FL-18506 (2014)\FL-18506.8.dwg, 8.1

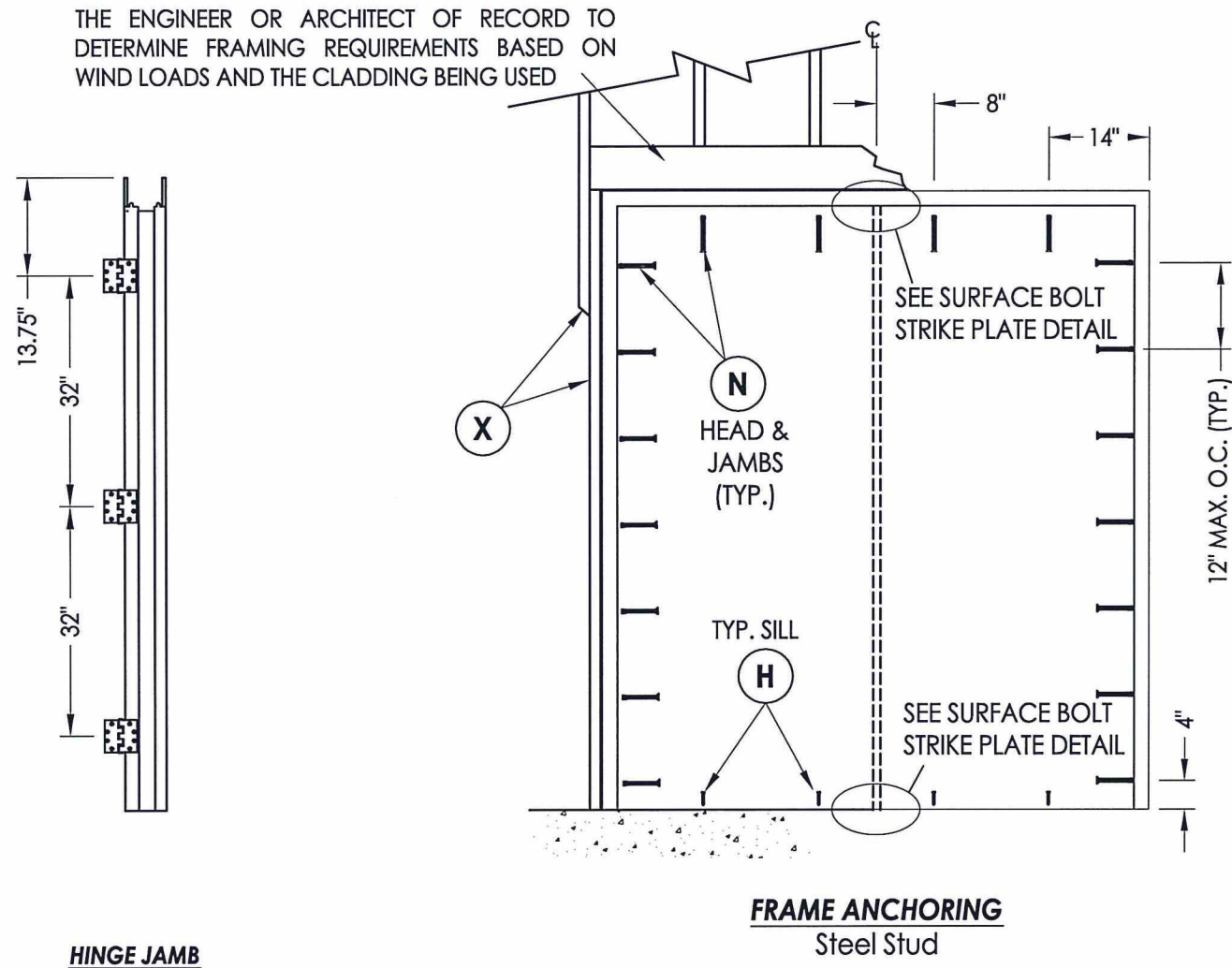

HINGE JAMB

FRAME ANCHORING
Steel Stud

CONCRETE ANCHOR NOTES:

1. Concrete screw locations may be adjusted to maintain a minimum 1" edge distance to mortar joints. If concrete screw locations noted as "MAX. O.C." must be adjusted to maintain the minimum edge distance to mortar joints, additional concrete screws may be required to ensure the maximum on center dimension is not exceeded.
2. Concrete anchor table:

ANCHOR TYPE	ANCHOR LOCATION	ANCHOR SIZE	MANUFACTURER	MIN. EDGE DISTANCE	MIN. EMBEDMENT
CONCRETE ANCHOR SCREW	SILL	1/4"	TAPCON® (ITW BUILDEX) ULTRACON® (ELCO) CRETE-FLEX® (ELCO) TAPPER+® (POWERS)	2-1/2"	1-1/4"

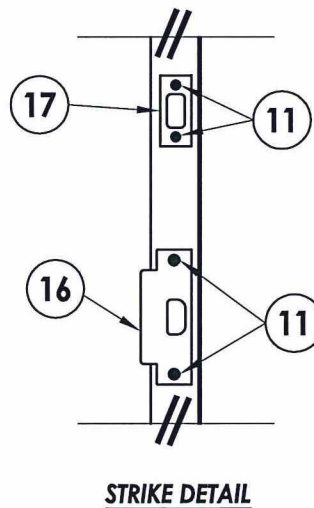

STRIKE DETAIL

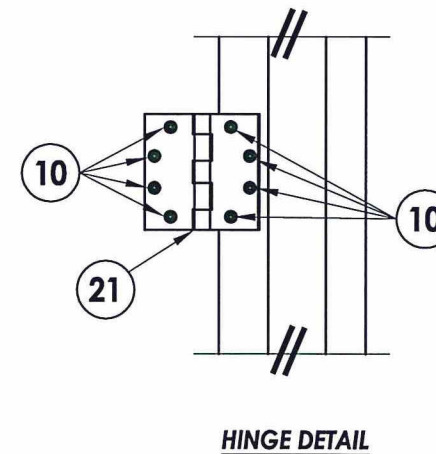

HINGE DETAIL

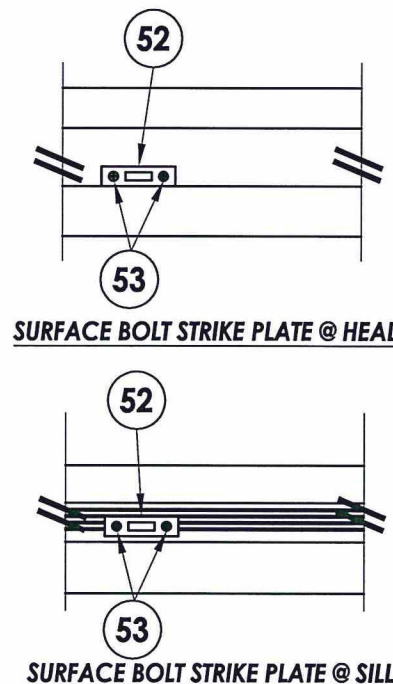

SURFACE BOLT STRIKE PLATE @ HEAD

SURFACE BOLT STRIKE PLATE @ SILL

LFS
12.17.15

Documents Prepared By:
Lyndon F. Schmidt
P.E. No. 43409

R.W. BUILDING CONSULTANTS, INC.
P.O. Box 230, Valrico, FL 33595
Phone No.: 813.659.9197
FBPE C.A. No. 9813

PRODUCT:	HMF EXPRESS	
PART OR ASSEMBLY:	ANCHORING DETAILS	
NO.	DATE	BY
REVISIONS		
DATE: 12/11/15		
SCALE: N.T.S.		
DWG. BY: JK		
CHK. BY: LFS		
DRAWING NO.: FL-18506.8		
SHEET 9 OF 11		

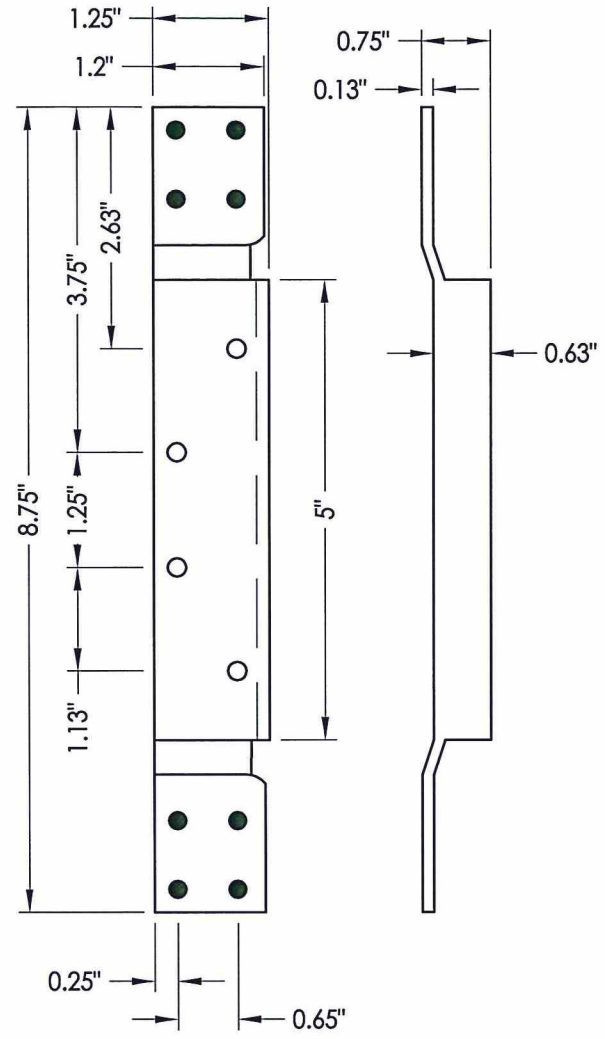

22 DOOR HINGE REINFORCEMENT

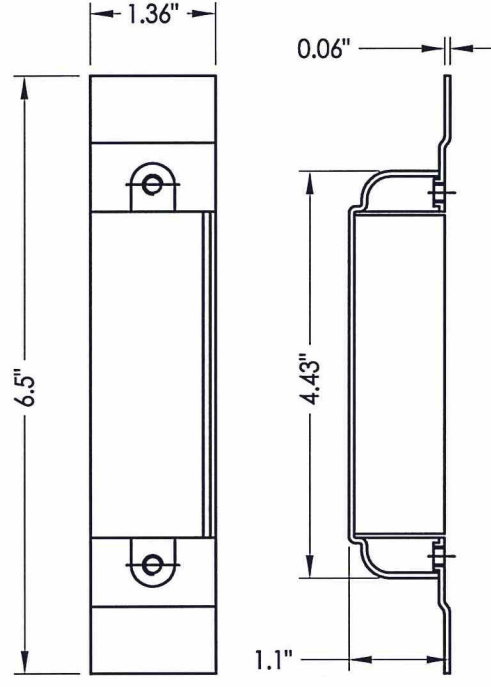

8 DUST BOX

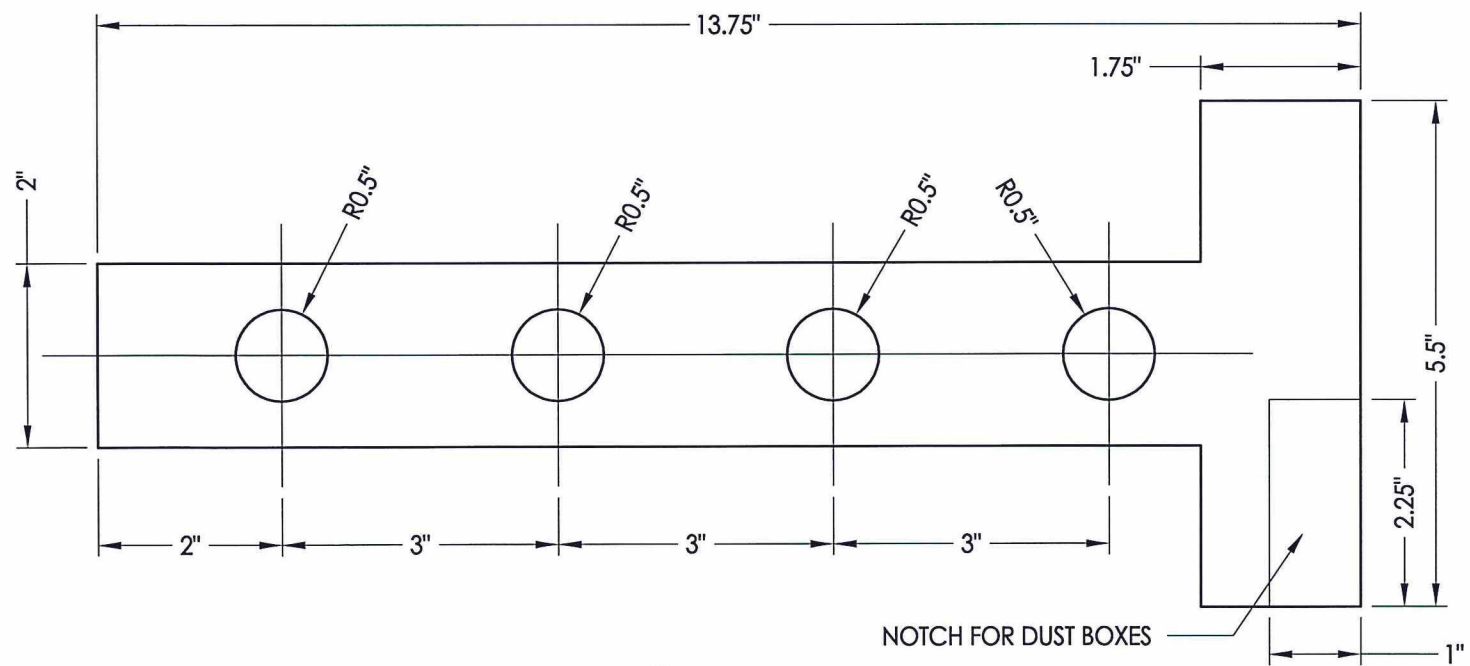

30 T ANCHOR
0.056" Thick Steel

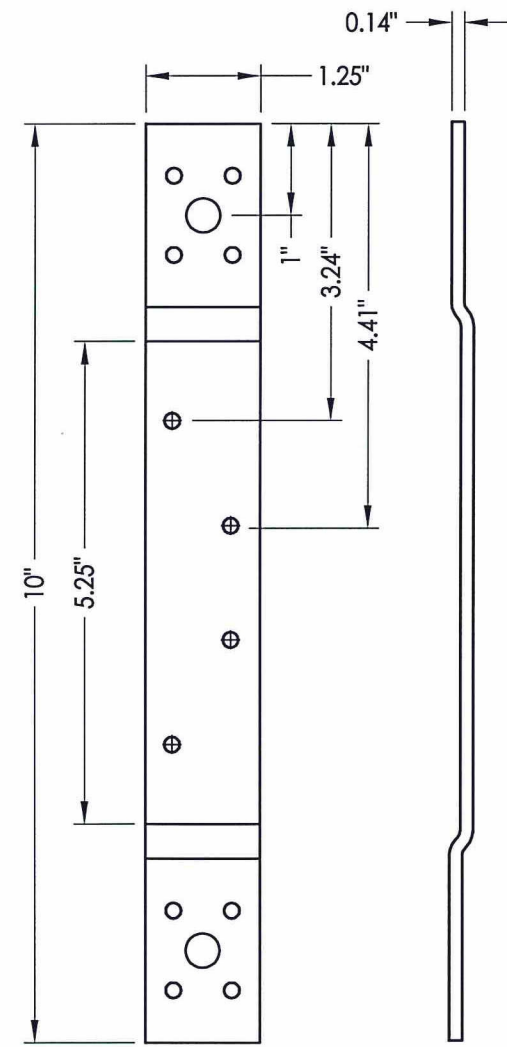

28 FRAME HINGE REINFORCEMENT

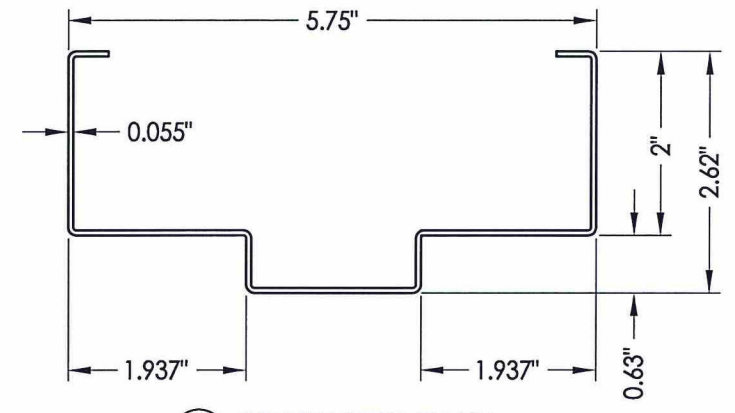

25 HOLLOW METAL FRAME
2" (Jamb)

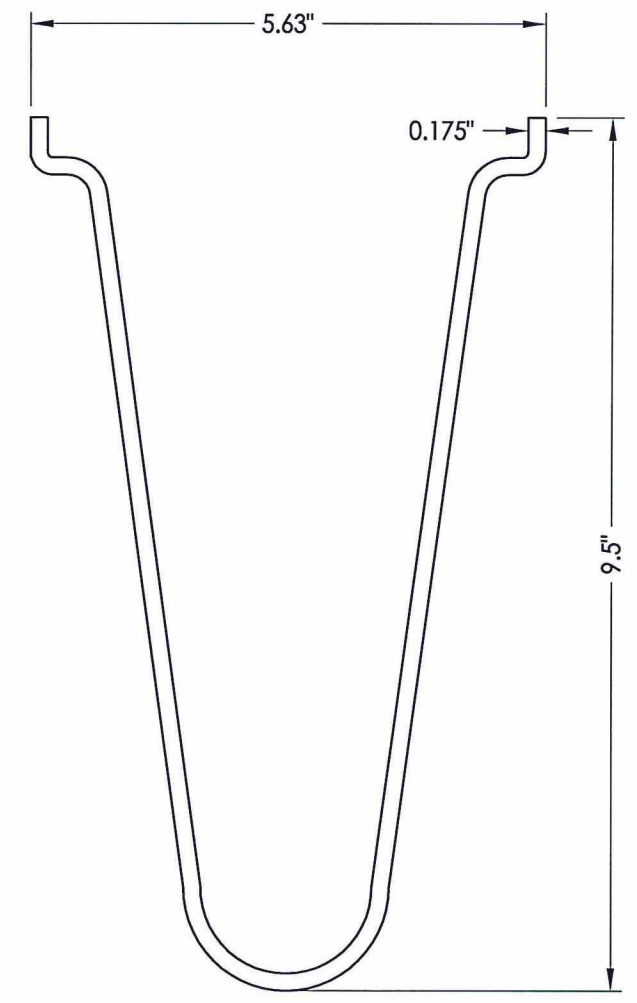

35 WIRE ANCHOR

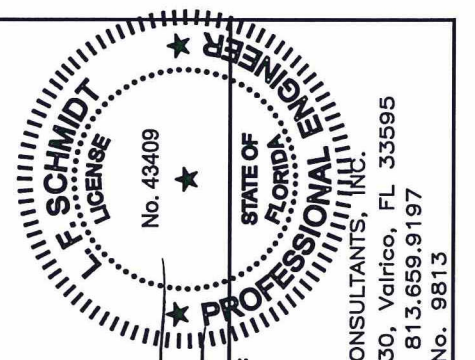

Documents Prepared By:
Lyndon F. Schmidt
P.E. No. 43409
LFS
12.17.15
PROFESSIONAL ENGINEER
R.W. BUILDING CONSULTANTS, INC.
P.O. Box 230, Valrico, FL 33595
Phone No.: 813.659.9197
FBPE C.A. No. 9813

PRODUCT:	HMF EXPRESS	
PART OR ASSEMBLY:	COMPONENTS	
NO.	DATE	BY
REVISIONS		
DATE:	12/11/15	
SCALE:	N.T.S.	
DWG. BY:	JK	
CHK. BY:	LFS	
DRAWING NO.:	FL-18506.8	
SHEET	10	OF 11

BILL OF MATERIALS		
ITEM #	DESCRIPTION	MATERIAL
C	1/4" MAX. SHIM SPACE	-
D	1/4" X 2-3/4" ELCO OR ITW CONCRETE SCREW	STEEL
E	MASONRY - 3,000 PSI MIN. CONCRETE CONFORMING TO ACI 301 OR HOLLOW BLOCK (GROUT FILLED) CONFORMING TO ASTM C90	CONCRETE
H	1/4" X 1-3/4" PFH CONCRETE SCREW (SEE CONCRETE ANCHOR TABLE)	STEEL
J	3/8" X 5" PFH DYNABOLT SLEEVE ANCHOR (SEE CONCRETE ANCHOR TABLE)	STEEL
M	3/8" X 5" LDT TAPCON CONCRETE SCREW (SEE CONCRETE ANCHOR TABLE)	STEEL
N	3/8" X 5" BOLT (ASTM A307) W/ NUT AND WASHER	STEEL
X	STEEL STUD (14 GA, Fu = 50 ksi, Fy = 33 ksi)	STEEL
1	STEEL DOOR PANEL	-
3	DOOR STOP	STEEL
8	DUST BOX	STEEL
9	ANCHOR BRACKET	STEEL
10	#12-24 X 1/2" PFH MACHINE SCREW	STEEL
11	#8 x 3/4" COMBINATION WOOD/MACHINE SCREW	STEEL
16	ANSI LATCH STRIKE	STEEL
17	DEADBOLT STRIKE	STEEL
19	DEADBOLT STRIKE REINFORCEMENT	STEEL
20	WEATHERSTRIP (PEMCO 303A)	NEOPRENE
21	4-1/2" X 4-1/2" X 0.125" HINGE	STEEL
22	DOOR HINGE REINFORCEMENT	STEEL
25	HOLLOW FRAME (2" JAMB) - 16GA (0.055" THK)	STEEL
28	FRAME HINGE REINFORCEMENT	STEEL
30	MASONRY 'T' ANCHOR	STEEL
35	WIRE ANCHOR	STEEL
40	THRESHOLD (NATIONAL GUARD 950)	ALUMINUM
50	ROCKWELL SURFACE BOLTS (580)	STEEL
51	1/4" X 2-1/2" PPH MS	STEEL
52	SURFACE BOLT STRIKE PLATE	STEEL
53	#12 X 5/8" FH SCREW	STEEL

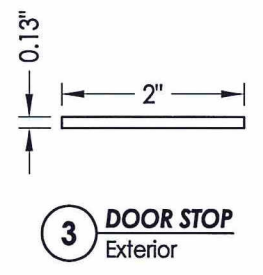
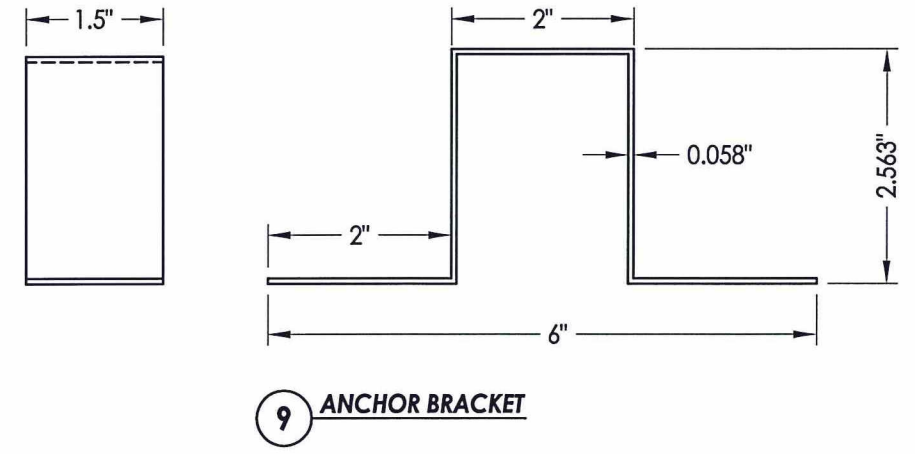
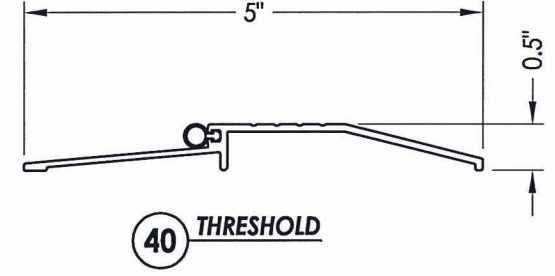

L.F. SCHMIDT
 LICENSE No. 43409
 STATE OF FLORIDA
 PROFESSIONAL ENGINEER

Documents Prepared By:
 Lyndon F. Schmidt
 P.E. No. 43409

BUILDING CONSULTANTS, INC.
 P.O. Box 230, Valrico, FL 33595
 Phone No.: 813.659.9197
 FBPE C.A. No. 9813

RW

PRODUCT: HMF EXPRESS	PART OR ASSEMBLY: BILL OF MATERIALS & COMPONENTS
NO. DATE	BY
REVISIONS	
DATE: 12/11/15	
SCALE: N.T.S.	
DWG. BY: JK	
CHK. BY: LFS	
DRAWING NO.: FL-18506.8	
SHEET 11 OF 11	